

SPECIFICATION OF XS SERIES

FEATURES

1. High impedance for common mode noise and low impedance for differential mode signal.
2. Large rated current available.
3. Wide band or sharp type impedance cure available.
4. SMD or DIP available.



APPLICATIONS

Prevention of common mode noise on signal Lines and power lines for computer related or electronic products.

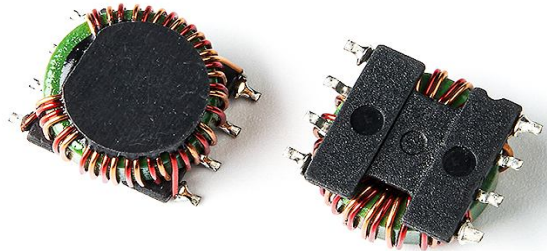

ORDERING CODE

J X S A 12 08 - 01

(1) (2) (3) (4) (5) (6) (7)

- (1) MATERIAL CODE
- (2) CORE TYPE
- (3) S : SMD , C : CAPPED SMD , D : DIP
- (4) ROHS CODE
- (5) MAX BASE DIMENSION(mm)
- (6) MAX HEIGHT(ABOVE PCB IN mm)
- (7) DESIGN CODE

APPEARANCE & DIMENSIONS

UNIT:mm

SIZE CODE	SHAPE		
XS 1208-01 Series	<p style="text-align: center;">TOP VIEW</p>	<p style="text-align: center;">SIDE VIEW</p>	<p style="text-align: center;">BOTTOM VIEW</p>
XS 1208-02 ,03 Series	<p style="text-align: center;">TOP VIEW</p>	<p style="text-align: center;">SIDE VIEW</p>	<p style="text-align: center;">BOTTOM VIEW</p>

※All the data listed in this catalogue are for reference only, King Core reserves the right to alter or revise the specifications without prior notification.

COMMON MODE CHOKE → XS TYPE

APPEARANCE & DIMENSIONS

UNIT:mm

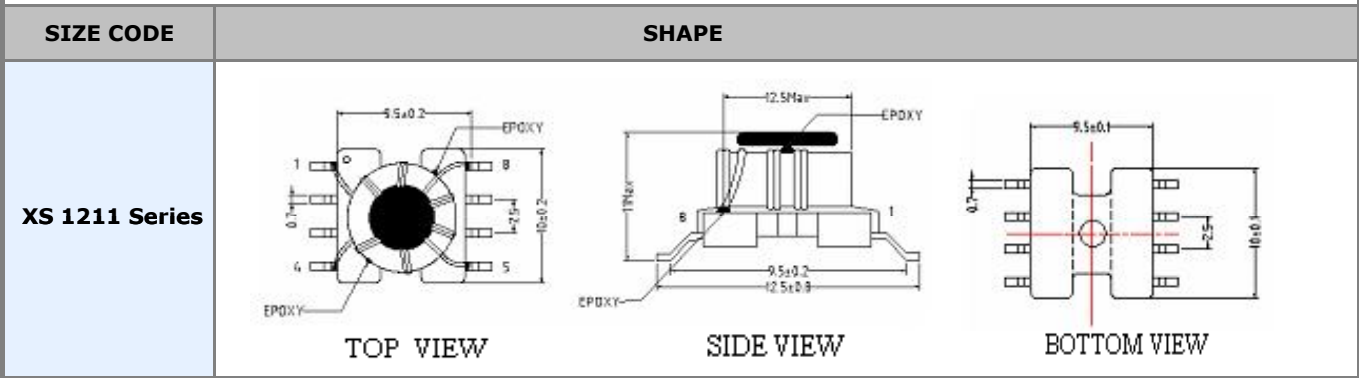

ELECTRICAL CHARACTERISTICS

ORDERING CODE	BASE	WINDING	WIRING	Z (Average) (Ω)	RATED CURRENT (mA)	RDC (Ω)max
DXSA1208-01	SMD-8P(12.5mm)	φ0.35*12.5TS*2	1-8,4-5	364min / 100MHz	3500	0.050
IXSA1208-01	SMD-8P(12.5mm)	φ0.35*12.5TS*2	1-8,4-5	453±25% / 100MHz	2500	0.050
JXSA1208-01	SMD-8P(12.5mm)	φ0.35*12.5TS*2	1-8,4-5	434±25% / 100MHz	4500	0.050
AXSA1208-02	SMD-8P(12.5mm)	φ0.35*18TS*2	1-8,4-5	1492 min / 1MHz	2500	0.080
AXSA1208-03	SMD-8P(12.5mm)	φ0.3*21TS*2	1-8,4-5	1567min/250KHz	2000	0.091
IXSA1211-01	SMD-8P(12.5mm)	φ0.45*6.5TS*2	1-8,4-5	500±25% / 100MHz	3000	0.100

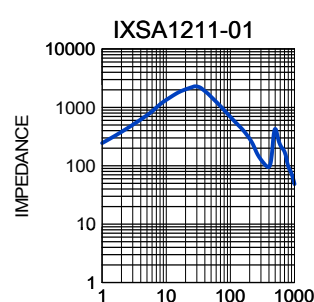
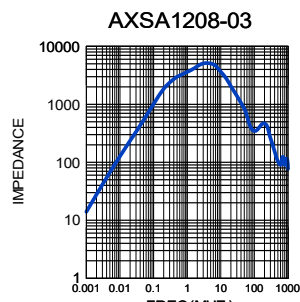
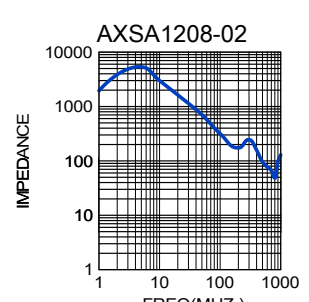
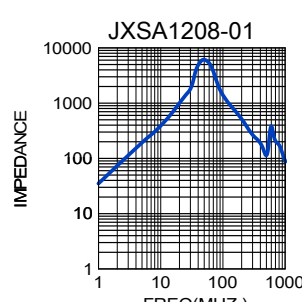
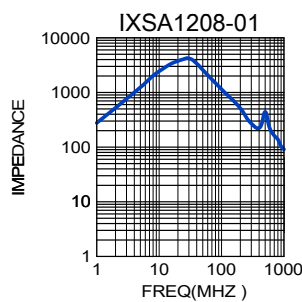
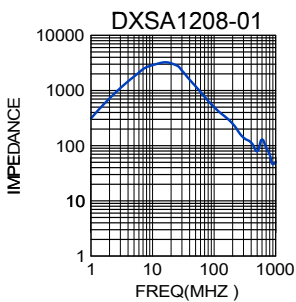

※All the data listed in this catalogue are for reference only, King Core reserves the right to alter or revise the specifications without prior notification.