

# SPECIFICATION OF RTB SERIES

## FEATURES

1. Low cost , High current.
2. Lowest EMI



## APPLICATIONS

Copying Machine , Display Monitor , ADSL Modem ,  
TV , Video Camera , Air Conditioner , Refrigerator ,  
Gaming Machine , Microwave Oven , Car Electronics ,  
Laundry Machine , Power supply applications , etc..

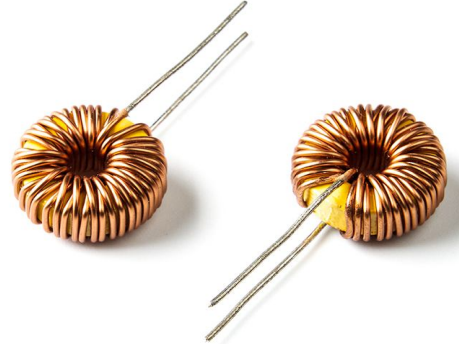

## ORDERING CODE

**RTB 5026 - 101 M U - 01**

**(1) (2) (3) (4) (5) (6)**

- (1) PRODUCT TYPE CODE
- (2) CORE PART NUMBER
- (3) INDUCTANCE
- (4) INDUCTANCE TOLERANCE ( K :  $\pm 10\%$ , M :  $\pm 20\%$ , N :  $\pm 30\%$  )
- (5) UL TUBE
- (6) DESIGN CODE

## CONFIGURATIONS

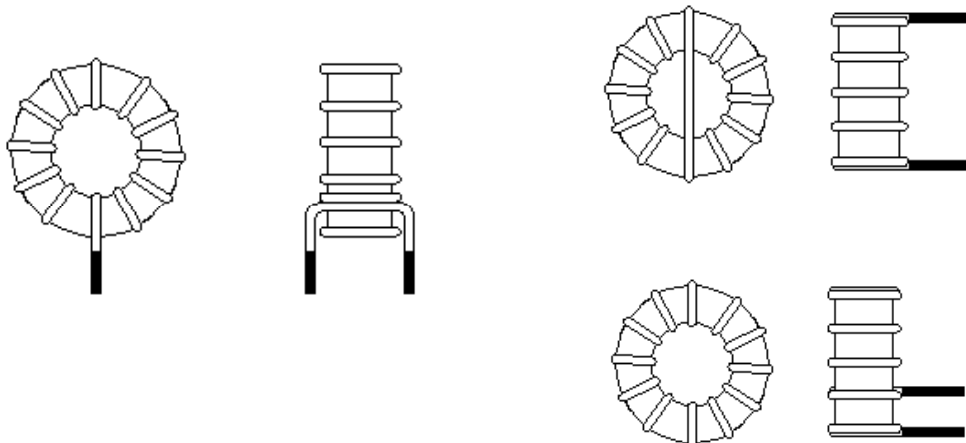

**\*Design as Customer's Requested Specifications.**

※All the data listed in this catalogue are for reference only, King Core reserves the right to alter or revise the specifications without prior notification.